



Thump and Shuttle Reactors for Catalytic Methane Combustion

Yasser Hourieh*

*Al-Sham Private University (ASPU), Damascus, Syria
Corresponding Author: Dr. Yasser Hourieh
Email ID: yasser-h@aspu.edu.sy

Abstract Thump and Shuttle reactors were designed and developed for methane catalytic combustion with air, and focused on intensifying chemical processes, with the aim of reducing reactor size and facilities to increase their efficiency, thus reducing the capital invested in them, as reflected in the cost of the produced energy. The interior parts of the reactor are covered with a one or two thin layer catalyst in order to exclude blocking processes by diffusion and improve the heat exchange between the catalyst and the reactor body. Thump reactor is useful, easy to use but its time consuming for each test of one catalyst and some troubles observed such as Rod metal bent, and this makes it difficult in taking out the inner part of the reactor. Shuttle reactor was a new idea and all tested catalysts were performed smoothly easily to use, time saving, silent, cause no damages in the reactors body, show's flexibility in works, and can test (2-4) catalysts samples consequently without demounting the reactor. Both reactors were equipped with all necessary control valves, and facilities.

Coated solid catalysts based on alumina and lanthanum were prepared by the (Sol-Gel) method, and used in preparing the gel. The interior metal reactor component was coated with this gel by the dipping method, then dried at laboratory temperature, and then calcined to (750°C). The thickness of coated solid catalysts was about (5-50) micrometer. The combustion of methane performed without flame at temperature about (700-800 °C), and nitrogen oxides formed in such conditions are much less compared to combustion by flame method.

Keywords Thump reactor, Shuttle reactor, Methane combustion, Thin layer catalyst, Sol-Gel catalysts, Coated catalysts, alumina Lanthanum and palladium

Introduction

Methane is burned in the gas phase of the flame method, according to the free roots mechanism, the oxidation reactions takes place very quickly, the temperature may rise to (1500-2000 °C) and at such high temperatures harmful nitrogen oxides are formed while the burner metal structures are damaged. Work must be done at selected concentrations of methane and air mixture [1-2]. The combustion of methane by coated catalyst performed without flame, offers many advantages, as it is done at much lower temperatures (700-800 °C). Nitrogen oxides formed in such conditions are much less compared to combustion by flame method, and it is also possible to work according to this method within a wide range of methane and air concentrations, which are silent burners, not accompanied by noise.

During the past two decades, intensifying chemical processes was a goal of many researches with the aim of reducing reactor size and facilities to increase their efficiency [3-5], thus reducing the capital invested in them, as reflected in the cost of the produced energy. Methane catalysts combustion, on average, compared to the combustion

of methane by the flame method, has received great attention to meet environmental needs and the desire to use energy sources effectively. The combustion of methane by catalyst without flame offers many advantages, being done at much lower temperatures at (700-800 °C), and nitrogen oxides that are formed in such conditions are much less compared to combustion made by flame method. It is also possible to work according to this method within a wide range of methane and air concentrations.

The inner part of the reactor is covered with a thin layer catalyst in order to exclude blocking processes by diffusion and improve the heat exchange between the catalyst and the reactor body, allowing the volume of the reaction unit to be condensed in a large proportion. The combustion of natural gases, of which methane constitutes the most components, has become one of the most important combustion reactions due to the abundance of natural gases, and despite that, it is the most difficult to oxidation process [3,4,11,17,18]. Methane is burned with air in the presence of a catalyst transforming into carbon dioxide and water vapor, according to the equations:

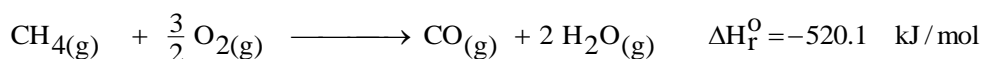
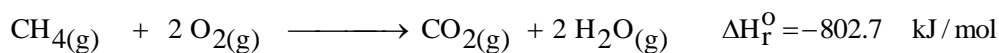

Oxygen is provided from the air that contains nitrogen, and a large amount of thermal energy is generated that can be utilized in various forms, including its exchange with another endothermic reaction, as in case of the hydrogen generation from the reaction between methane and water vapor [9,19,20].

Materials and Methods

Thump Reactor

A Thump reactor was used, designed specifically for laboratory experiments in methane combustion using air as oxygen source. It consists of a metal cylinder representing the body of the reactor made of stainless steel (SST) and closed from one side (Thump Shape), its outer diameter (20 mm) and internal diameter of (14 mm) and a length of (200 mm). A cylindrical tube (Rod) made of stainless steel (SST), with (6.35 mm) outer diameter and (4 mm) inner diameter placed at the center of the reactor and connected at one end with appropriate connections that allow gases to enter through the Rod and preheated while the other end is inside the reactor, so the gases can inter through inner central tube contacted with catalyst layer at the rod outer side surface (or inner side) and exit from the reactor through a hole at the stopper of the reactor. The thin layer catalyst was coated to a fixed long at outside and inner side of the central tube (Rod), dried and calcined, then inserted into the center of the reactor through the metal stopper. Two thermocouples were located parallel to the central tube inside the reactor and near the catalyst surface. This reactor design provides the possibility to coat the catalyst at:

- a) Rod outside only.
- b) Rod outside and inside.
- c) Reactor body wall inside.

In this way we can load and control the quantity of the catalyst so that the catalyst will be in the center of the reactor, and gases entering and leaving in contact with the catalyst. Figure (1) shows a diagram of the reactor, central tube placement, temperature sensors, cylindrical electric furnace, valves and control means. Figure (2) shows the Preliminary diagram of the gas flow control unit and catalysts test. The Thump reactor worked very well but its time consuming for each experiment. After so many experiments using this design of the reactor, we advise to use one coat of the catalyst (Outer side of the Rod) because we noticed that there is a temperature rise during the reaction process which caused the central tube (Rod) to bent slightly, so that we faced difficulties to take it out of the reactor and this caused damage in the catalyst layer. The troubles faced in the Thump reactor push us to design a more advanced flexible reactor.



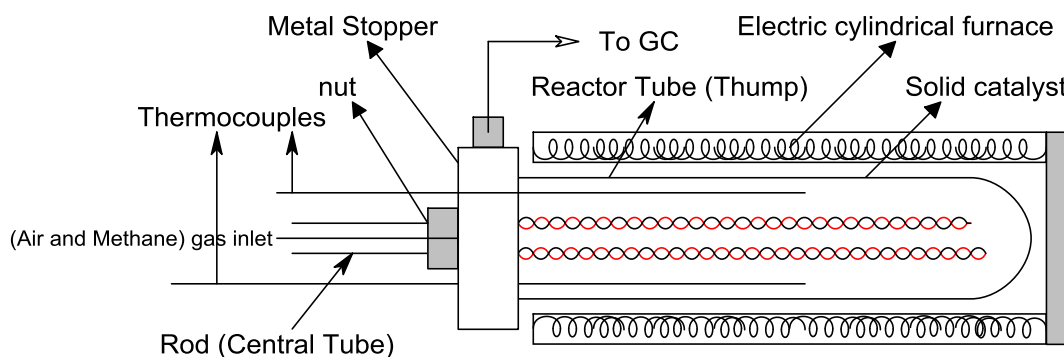

Figure 1: Diagram of the Thump reactor, central tube placement, temperature sensors and cylindrical electric furnace

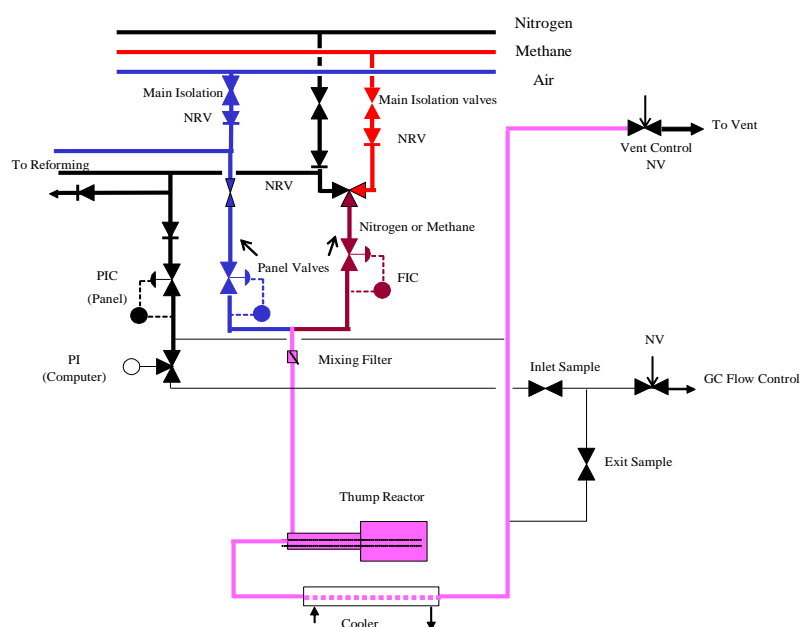

Figure 2: Preliminary diagram of the gas flow control unit and catalysts test

Shuttle Reactor

A shuttle reactor was used, designed specifically for laboratory experiments and its dimensions were determined after a mathematical model. It consists of a cylinder metal representing the body of the reactor made of stainless steel (SST) with an internal diameter of (9 mm) and a length of (150 mm). It is connected at both ends with appropriate connections that allow gases to enter and exit, and located in its center two or three or more cylindrical tubes (Rods) made of stainless steel (SST), each of them (6.35 mm) in diameter and connected to each other via a spiral serration pierced at its center. The catalyst is coated at the end of each piece of the central tube near the joint, treated and prepared for test, then it was inserted into the reactor to meet with its counterpart and connect to it through the spiral gear, and thus it is possible to control the placement of the catalyst coated part of the tube so that the first catalyst is located in the center of the reactor, as well as the path of the gases entering and leaving in contact with the catalyst under test. If the second catalyst is to be tested, then the central tube must be moved to the left or

right so that the required catalyst zone becomes in the center of the reactor body and thus the central tube can be moved left or right like a shuttle, and a tube coated with a new catalyst can also be inserted and connected through the spiral tooth with the second counterpart of the tube. Figure (3) shows a diagram of the reactor, central tube placement and temperature sensors. The shuttle reactor design gives the following possibilities of thin layer catalyst coating and testing:

- Catalyst coating of inner surface of the reactor only + gas preheat.
- Catalyst coating of inner surface of the reactor + outer side of central tube+ with or without gas preheat.
- Catalyst coating of inner surface of the reactor + outer side and inner side of central tube + with or without gas preheat

The shuttle reactor design worked very well, time saving for each experiment in comparison with Thump reactor. If the inner wall of the reactor is coated, we have to demount the reactor in each experiment and this is time consuming, for laboratory experiments it's better not to coat with catalyst the inner wall of the reactor and its quite sufficient to coat outer side and inner side (if needed) of the central tube, thus the shuttle movements of the central tube proceeds quite well.

Control and Measurements

Both designed reactors were equipped with a laboratory pilot plant control circuit contains horizontal cylindrical electric furnace and the reactor will be inside the furnace. An external control circuit was manufactured and equipped with all necessary measuring and control facilities, such as gas control valves (FIC), micro filters, mixer of methane and air, pressure control (PIC), and all controllers are connected to computer that register all data. Samples are taken periodically each is (10.8 min.), and the reaction products were analyzed via gas chromatograph. Figures (3 and 4) shows the diagram of shuttle reactor and the control unit.

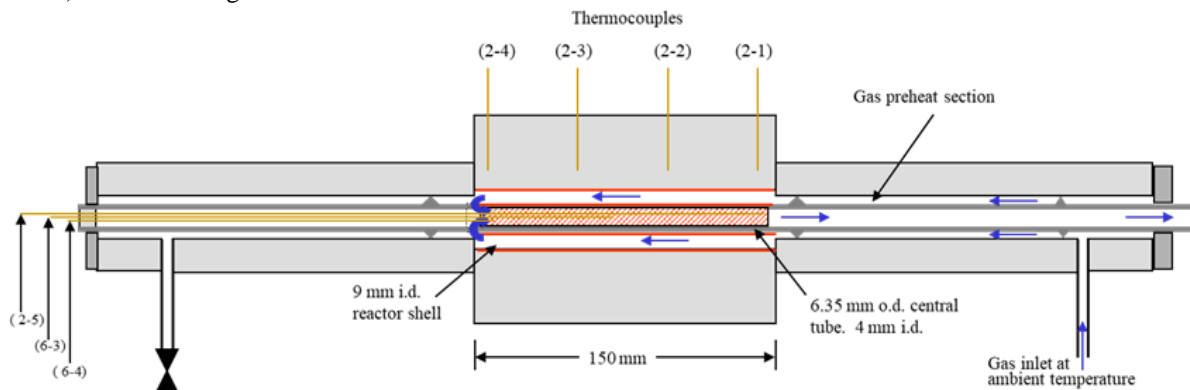

Figure 3: Reactor Shell and central tube (inside and outside) coated with thin layer catalyst + gas preheat

Raw materials used in the laboratory experiments

Alumina powder made by (CONDEA Chemie GmbH), deionized water, Pure Lanthanum and palladium nitrate, was used for gel preparations. Methane gas which is packed in compressed cylinders, as well as air, both of which we got from the British company (BOC), and the rest of the materials are pure.



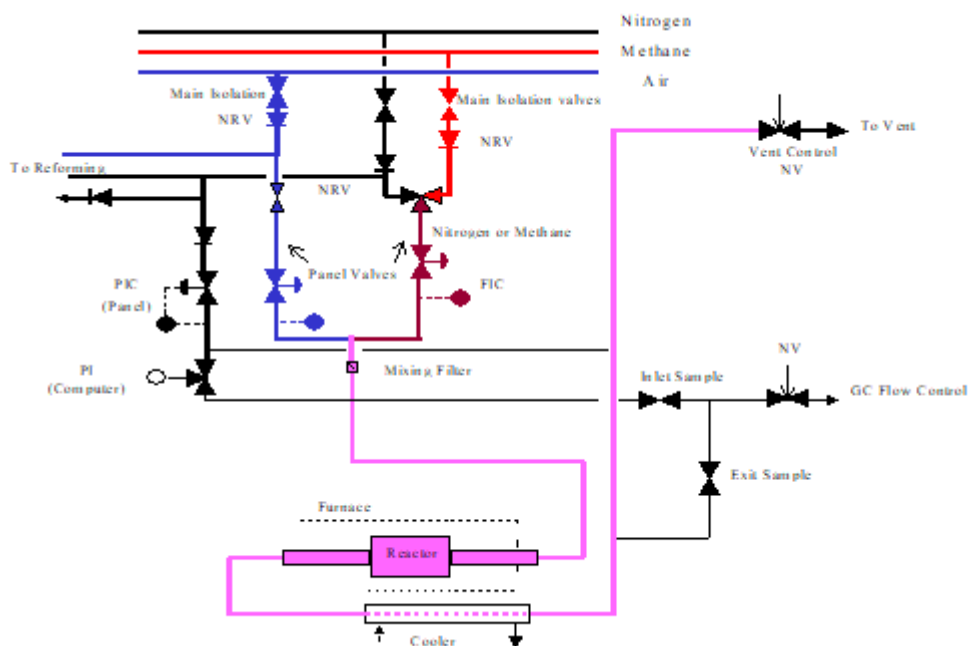

Figure 4: Preliminary diagram of the gas flow control unit and catalysts test

A chromatographic analyzer (ATI Unicam-SPEC 2690) was used, containing three serial columns made of stainless steel separated from each other by pneumatic valves in a programmatic manner and connected with the computer, two for separating moisture and analysis contains(Haye Sep Q filling), and the third contains (Mol. Sieve 13 X AT), and Helium carrier gas flow line. The analysis process is controlled through these columns, detected in thermal detector (TCD) and results are recorded. A device for carbon monoxide detector and alarm was necessary to detect CO traces around the working area. Figure (5) shows one example of the chromatographic diagrams that was recorded during the experiments.

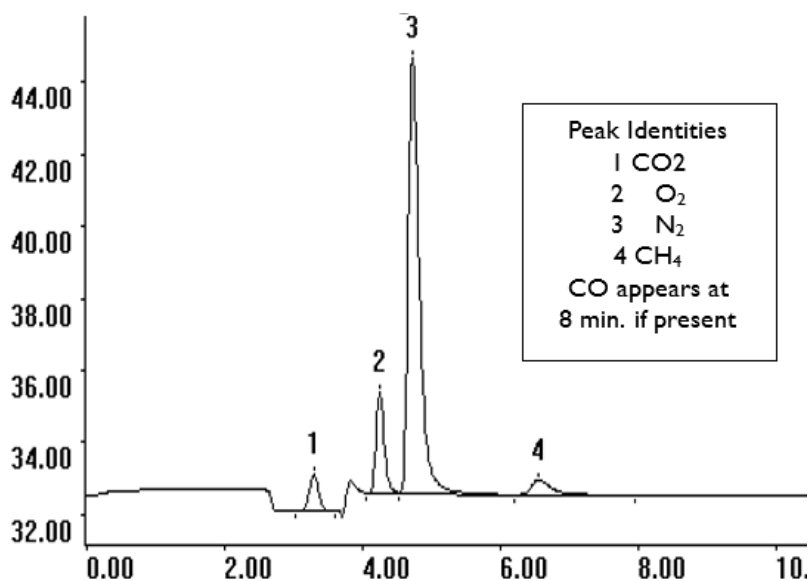

Figure 5: Example of a typical chromatographic diagram that includes reaction products analysis

Catalyst composition

After a comprehensive review of references and periodicals, it has become clear for us that the heterogeneous catalysts for methane combustion reaction is effective alumina and that it was chosen because it has an acceptable qualitative surface (even at high temperatures) that secures the penetration of methane molecules into its pores in order to come into contact with the active surface of the catalyst and the possibility of preparing it in a gelatinous form that helps in coating the catalyst in the form of a thin layer, so that we can use it in the compact reactor. In addition, it can be used to load with some noble metals such as palladium or platinum in many ways [6-7], which showed best results, including placing it on the surface of the catalyst by impregnation and chemically activation. Lanthanum was added to the gel formulation and has an important role in the adhesion of the catalyst on the metal surface, because Peeling effect was observed on most catalysts that were prepared from alumina alone or after adding the active metal to it during the drying or calcination process.

Gel preparation

This was done by using the technique called (Sol-gel) [5]. According to this method, the catalyst gel is prepared by mixing the required amount of water (de-ionized conveyor less than a quarter of a micro-Siemens), concentrated nitric acid, Lanthanum nitrate, palladium nitrate (or other noble metals) and mixed well, then pure alumina powder was added gradually using a laboratory mechanical mixer equipped with a mixing arm, and started at a suitable speed with continued stirring for half an hour until gel is formed, and complete homogeneity is attained. Gel has been examined from time to time to ensure that it is free of certain clots. The gel has shown an almost plastic behavior, so its viscosity has been changing with time and with stirring. Well mixed gel exhibits less viscosity and as soon as stirring stops the gel becomes more viscous.

Gel catalyst coating and drying

The metal surface (ex. Rod) is prepared by cleaning outside and inside surfaces using dilute hydrochloric acid, then washed by distilled water and dried. The metal surface was coated with the dipping method for the outer metal surfaces that could be dipped into the container containing the gel by contacting the metal with the gel for twenty seconds and then slowly taking it out of the gel. The inner metal surfaces were coated by using a syringe that allowed the gel to be introduced into the internal cavities and then withdrawn in an opposite motion. Our experiments have shown that the drying process is very important for obtaining a homogeneous layer that does not contain cracks or peeling at any of its parts. Following many experiments, we found that the best way to dry the coated catalyst is to suspend the metal piece that was coated with gel in the laboratory atmosphere and temperature for two hours, away from air currents, hence it dries very slowly and homogeneously. We also concluded that controlling gel viscosity is an important factor and this can be done by adjusting the appropriate composition and the preparation method. The gel acidity degree is (pH = 1.0) for the adopted compositions.

Calcining the catalyst thin layer

The metal piece (or Rod) , coated with the catalyst layer, was placed in an electric horizontal calcining furnace programmed to raise its temperature at (1 °C / min.) to (750 °C), and to set fixed at this temperature for two hours, then the temperature was reduced to normal at (2 °C/ min.) After calcination the catalyst layer becomes of a thickness of (5-50 microns) and be ready to be tested for its activity in the methane conversion reaction to carbon dioxide and water vapor. We got structures that showed strong adhesion to the metal, as we could not remove it using parchment paper except with great difficulty. Moreover, catalyst layer was not affected when used in reaction at high temperatures.

Catalyst activity test

Prepared catalysts were supposed for activity test by using the Thump and Shuttle reactors. The methane and air flows were measured on the basis that the reactor secures an estimated amount of heat of (10kW / m²), representing



the possible limit for the reactor to be economical. Based on this, methane and air flows were calculated and all experiments were completed within the limits of providing this amount of heat. Some selected prepared catalysts show high conversion of methane.

Results and Discussions

A Thump reactor was used, designed specifically for laboratory experiments in methane combustion using air as oxygen source, works well, and shows sufficient flexibility, easy to use, but its time consuming for each experiment. After so many experiments using this design, it's not recommended to coat the catalyst on the inner wall of the reactor because it's very difficult to remove the catalyst layer and need to manufacture a new metal reactor for each tested catalyst. It's recommended to use one coat of the catalyst (outer side of the Rod) because we noticed a temperature rise during the reaction process which caused the central tube (Rod) to slightly bent and we have faced difficulties to take it out of the reactor and this caused damage in the catalyst layer. Troubles faced in the Thump reactor have pushed us to design a more advanced flexible reactor.

The designed and used shuttle reactor shows more flexibility, easy to use, time saving and we highly recommend it for similar laboratory experiments. We focused on intensifying chemical processes with the aim of reducing reactor size and facilities to increase their efficiency, thus reducing the sum invested in them, as reflected in the cost of the produced energy. The used Sol-gel method for preparing the alumina catalyst gel is appropriate, and we could coat the catalyst on the metal piece or rod easily, and in case of the need or desire to increase the amount of the catalyst for surface unit, we can resort to the method of scratching the surface or making a reactor metal that has surfaces with different geometry shapes. It is quite satisfactory to work with one layer of the catalyst. The composition of the catalyst and the proportion of lanthanum has played an important role in the adhesion of the catalyst on the metal, and we got compositions that show powerful adhesion on the metal.

Conclusions

- Thump reactor works well but it takes some times for each activity test and needs to demount the reactor for each catalyst test beside difficulties in taking out the rod outside of the reactor.
- Shuttle reactor is a very good design that shows: flexibility, easy to use, ensures time saving, possibility of testing several catalysts without demounting the reactor, works continually, and can be used for similar reactions and for similar laboratory experiments. Its highly recommend.
- Intensifying chemical processes is the aim of reducing reactor size and facilities to increase their efficiency, thus reducing the sum invested in them, as reflected in the cost of the produced energy.
- The so-called Sol-gel method is suitable for catalyst gel preparations and metal surface coating.
- Controlling catalyst gel viscosity is an important factor and it's adjusted by the appropriate composition and the preparation method.
- The catalyst gel has shown an almost plastic behavior, so its viscosity changing with time and stirring, and its properties can be preserved and stored for a long time (more than one month) and must be mixed well before use.
- Drying process is important for obtaining a homogeneous coated layer that does not contain cracks or peeling at one of its parts.
- It is quite satisfactory to work with one layer of the catalyst.
- To increase the amount of the catalyst for one surface unit, we can resort to the method of scratching the surface or making a reactor metal that has surfaces with different geometry shapes.

References

- [1]. Marcus F.M.Zwinkels; Sven G. Jaras and P.Govind Menon ; (1993), Catal. Rev.- Sci. Eng; 35(3), 319-358.
- [2]. Glassman, I; Combustion. 3rd ed. (1996), London: Academic Press.
- [3]. Anderson, R.B; et al; (1961), Catalytic Oxidation of Methane. Ind. Eng. Chem; 53(10): p. 809-812.
- [4]. S.T. Kolaczowski; R.E. Hayes; (1998), "Introduction To Catalytic Combustion" (1998).



- [5]. G.M. Pajonk; (1995), Heterogenous Chemistry Reviews;vol 2 ; P(129-141).
- [6]. N.A. Koryabkina; R.A.Shkrabina; V.A.Ushakov; Z.R.Ismagilov; "Synthesis of a mechanically strong and thermally stable alumina support for catalysts used in combustion processes; (1996) "Catalysis Today, (29); p(427-431).
- [7]. Marcus F.; M.Zwinkels; Sven G. Jaras and P. Govind Menon; (1993); Catal. Rev. Sci. Eng; 35(3), p 319-358.
- [8]. Andrey J.Zarur & Jackie Y.Ying "Reverse microemulsion synthesis of nanostructured complex oxide for catalytic combustion"; (January 2000); Nature, vol (403), P.(74).
- [9]. Ronald F. Probst ; R. Edwin Hicks; " Synthetic Fuels "
- [10]. N.N. Greenwood ; A. Eamshaw ; (1997); Chemistry of Elements; II – Ed (P.1152) .
- [11]. Bruce C. Gates, James R. Ketzner, G. C. A. Sehuit; (1978); Chemistry of Catalytic Processes; McCraw-Hill, New York.
- [12]. Martyn V.Twigg ; (1989); Catalyst Handbook , sec. Ed. by Wolfe Publishing Ltd.
- [13]. Beguin B; Garbowski E ; and Primet M ; Stabilisation of alumina by addition of Lanthanum; Appl. Cat. 75 , (119-132) .
- [14]. David R; Lide V; (1996-1997); Handbook of chemistry and Catalysis ; 77th edition CRC Press.
- [15]. I Udrea, D Crisan, Y Hourieh; (1994); Methane conversion with carbon oxide, support and natural influence upon the Nickel- catalyst properties; revista de chemie; (45-12), p(1066-1071).
- [16]. Nak Aramoubi; JG Toma; BA Tarboush; (2018); Catalyst design for dry reforming of methane: analysis reviews; Energy reviews, Elsevier.
- [17]. G Italiano, C Espro, F Arena, A Parmaliana; (2009); Doped Ni thin layer catalysts for catalytic decomposition of natural gas to produce hydrogen; Applied Catalysis A - Elsevier.
- [18]. H Butcher, BA Wilhite; (2016); Enhancing catalyst effectiveness by increasing catalyst film thickness in coated-wall microreactors: Exploiting heat effects in catalytic methane steam micro-reformers; Chemical Engineering Science; Elsevier.
- [19]. Y Fan, M Sun, C Miao, Y Yue, W Hua, Z Gao; (2021); Morphology effects of nanoscale Er₂O₃ and Sr-Er₂O₃ catalysts for oxidative coupling of methane; Catalysis Letters, Springer.
- [20]. M Zhao; S Ke; H Wu; W Xia; H Wan; (2019); Flower-like Sr-La₂O₃ Microspheres with Hierarchically Porous Structures for Oxidative Coupling of Methane; Industrial &Engineering, ACS Publications.

